

Reference Design using the HC55185 and the AK2306/2306LV Dual PCM CODEC

The purpose of this application note is to provide a reference design for the HC55185 and AK2306/2306LV Dual PCM CODEC.

The network requirements of many countries require the analog subscriber line circuit (SLIC) to terminate the subscriber line with an impedance for voiceband frequencies which is complex, rather than resistive (e.g. 600Ω). The HC55185 accomplishes this impedance matching with a single network (R_S Figure 1) connected between the VTX pin and the -IN pin.

The AK2306/2306LV Dual PCM CODEC includes Selectable A-law/μ-law function, Internal Gain Adjustment from +6dB to -18dB by 1dB steps control and a selectable 16Hz/20Hz Ring Tone Generator.

Discussed in this application note are the following:

- 2-wire impedance matching
- Receive gain (4-wire to 2-wire) and transmit gain (2-wire to 4-wire) calculations
- Reference design for both 600Ω and 220Ω +820Ω||115nF Complex Impedance

Impedance Matching

Impedance matching of the HC55185 to the subscriber load is important for optimization of 2 wire return loss, which in turn cuts down on echoes in the end to end voice communication path. Impedance matching of the HC55185 is accomplished by making the SLIC's impedance (Z_O, Figure 1)

equal to the desired terminating impedance Z_L, minus the value of the protection resistors (R_P). The formula to calculate the proper R_S for matching the 2-wire impedance is shown in Equation 1.

$$R_S = 133.3 \cdot (Z_L - 2R_P) \tag{EQ. 1}$$

Equation 1 can be used to match the impedance of the SLIC and the protection resistors (Z_{TR}) to any known line impedance (Z_L). Figure 1 shows the calculations of R_S to match a resistive and 2 complex loads.

EXAMPLE 1:

Calculate R_S to make Z_{TR} = 600Ω in series with 2.16μF. R_P = 49Ω.

$$R_S = 133.3 \left(600 + \frac{1}{j\omega 2.16 \times 10^{-6}} - (2)(49) \right) \tag{EQ. 2}$$

R_S = 66.9kΩ in series with 16.2nF. Note: Some impedance models, with a series capacitor, will cause the op amp feedback to behave as an open circuit DC. A resistor with a value of about 10 times the reactance of the R_S capacitor (2.16μF/133.3 = 16.2nF) at the low frequency of interest (200Hz for example) can be placed in parallel with the capacitor in order to solve the problem (491kΩ for a 16.2nF capacitor).

EXAMPLE 2:

Calculate R_S to make Z_{TR} = 220 + 820//115nF. R_P = 49Ω.

$$Z_T = 133.3 \left(220 + \frac{820}{1 + j\omega 820(115) \times 10^{-9}} - (2)(49) \right) \tag{EQ. 3}$$

R_S = 16.26kΩ in series with the parallel combination of 109.3kΩ and 862pF.

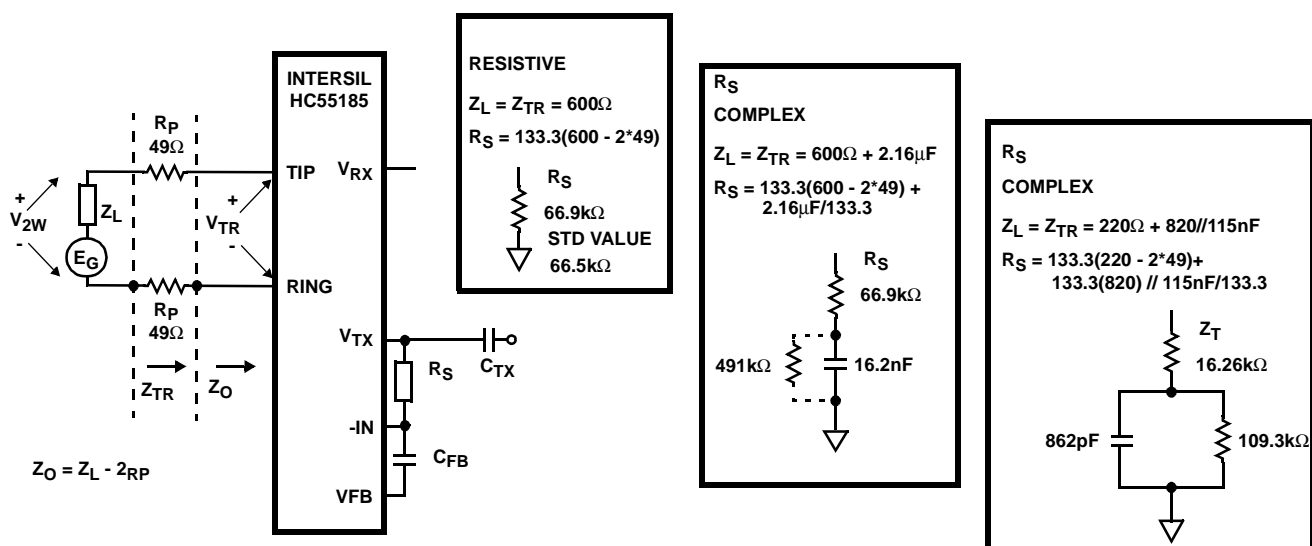

FIGURE 1. IMPEDANCE MATCHING

SLIC in the Active Mode

Figure 2 shows a simplified AC transmission model of the HC55185 and the connection of the AK2306 to the SLIC. Figure 3 shows a simplified AC transmission model of the HC55185 and the connection of the “Low Voltage” AK2306LV to the SLIC. The Low Voltage AK2306LV CODEC requires a different connection to the HC55185 to achieve the voltage gain required at tip and ring without clipping the output signal of the CODEC.

The following analysis is performed with the AK2306 CODEC connection. Circuit analysis of the “Low Voltage” circuit is left for the reader. Circuit analysis of the HC55185 yields the following design equations:

The Sense Amplifier is configured as a 4 input differential amplifier with a gain of 3/4. The voltage at the output of the sense amplifier (V_{SA}) is calculated using superposition. V_{SA1} is the voltage resulting from V_1 , V_{SA2} is the voltage resulting from V_2 and so on (reference Figure 2).

$$V_{SA1} = -\frac{3}{4}(V_1) \quad (\text{EQ. 4})$$

$$V_{SA2} = \frac{3}{4}(V_2) \quad (\text{EQ. 5})$$

$$V_{SA3} = -\frac{3}{4}(V_3) \quad (\text{EQ. 6})$$

$$V_{SA4} = \frac{3}{4}(V_4) \quad (\text{EQ. 7})$$

$$V_{SA} = [(V_2 - V_1) + (V_4 - V_3)]\frac{3}{4} = [\Delta V + \Delta V]\frac{3}{4} \quad (\text{EQ. 8})$$

Where ΔV is equal to $I_M R_{SENSE}$ ($R_{SENSE} = 20\Omega$)

$$V_{SA} = 2(\Delta I_M \times 20)\frac{3}{4} = \Delta I_M 30 \quad (\text{EQ. 9})$$

The voltage at V_{TX} is equal to:

$$V_{TX} = -V_{SA}\left(\frac{R_S}{8K}\right) = -\left(\frac{R_S}{8K}\right)\Delta I_M 30 \quad (\text{EQ. 10})$$

V_{TR} is defined in Figure 2, note polarity assigned to V_{TR}

$$V_{TR} = 2(V_{RX} + V_{TX}) \quad (\text{EQ. 11})$$

Setting V_{RX} equal to zero, substituting Equation 10 into Equation 11 and defining $Z_O = -V_{TR}/\Delta I_M$ will enable the user to determine the require feedback to match the line impedance at V_{2W} .

$$Z_O = \frac{1}{133.33}R_S \quad (\text{EQ. 12})$$

Z_O is the source impedance of the device and is defined as $Z_O = Z_L - 2R_P$. Z_L is the line impedance. R_S is defined as:

$$R_S = 133.33(Z_L - 2R_P) \quad (\text{EQ. 13})$$

Node Equation at HC55185 V_{RX} input

$$I_X = \frac{V_{RX}}{R} + \frac{V_{TX}}{R} \quad (\text{EQ. 14})$$

Substitute Equation 10 into Equation 14

$$I_X = \frac{V_{RX}}{R} - \left(\frac{R_S \Delta I_M 30}{8K}\right) \quad (\text{EQ. 15})$$

Loop Equation at HC55185 feed amplifiers and load

$$I_X R - V_{TR} + I_X R = 0 \quad (\text{EQ. 16})$$

Substitute Equation 15 into Equation 16

$$V_{TR} = 2V_{RX} - \left(\frac{R_S \Delta I_M 60}{8K}\right) \quad (\text{EQ. 17})$$

Substitute Equation 12 for R_S and $-V_{2W}/Z_L$ for ΔI_M into Equation 17.

$$V_{TR} = 2V_{RX} + \frac{Z_O V_{2W}}{Z_L} \quad (\text{EQ. 18})$$

Loop Equation at Tip/Ring interface

$$V_{2W} - I_M 2R_P + V_{TR} = 0 \quad (\text{EQ. 19})$$

Substitute Equation 18 into Equation 19 and combine terms

$$V_{2W} \left[\frac{Z_L + Z_O + 2R_P}{Z_L} \right] = -2V_{RX} \quad (\text{EQ. 20})$$

where:

V_{RX} = The input voltage at the V_{RX} pin.

V_{SA} = An internal node voltage that is a function of the loop current and the output of the Sense Amplifier.

I_X = Internal current in the SLIC that is the difference between the input receive current and the feedback current.

I_M = The AC metallic current.

R_P = A protection resistor (typical 49.9 Ω).

R_S = An external resistor/network for matching the line impedance.

V_{TR} = The tip to ring voltage at the output pins of the SLIC.

V_{2W} = The tip to ring voltage including the voltage across the protection resistors.

Z_L = The line impedance.

Z_O = The source impedance of the device.

HC55185 Receive Gain (V_{RX} to V_{2W})

4-wire to 2-wire gain across the HC55185 is equal to the V_{2W} divided by the input voltage V_{RX} , reference Figure 2. The receive gain is calculated using Equation 20.

Equation 21 expresses the receive gain (V_{RX} to V_{2W}) in terms of network impedances. From Equation 13, the value of R_S was set to match the line impedance (Z_L) to the HC55185 plus the protection resistors ($Z_O + R_P$). This results in a 4-wire to 2-wire gain of -1, as shown in Equation 21.

$$G_{4-2} = \frac{V_{2W}}{V_{RX}} = -2 \frac{Z_L}{Z_L + Z_O + 2R_P} = -2 \frac{Z_L}{Z_L + Z_L} = -1 \quad (\text{EQ. 21})$$

Receive Gain Across the System

The receive gain across the system is defined as the gain from DR to the phone (V_{2W}). With the receive gain through the HC55185 set to 1, the receive gain across the system is entirely controlled by programming the AK2306. The AK2306 can program the receive gain across the system from +6dB to -18dB in 1 dB increments (reference Figure 4).

If more precise gain increments are required, the AMPR amplifier can be used to adjust the overall Receive gain ($R6/R7$).

Transmit Gain Across HC55185 (E_G to V_{TX})

The 2-wire to 4-wire gain is equal to V_{TX}/E_G with $V_{RX} = 0$, reference Figure 2.

Loop Equation (EQ. 22)

$$-E_G + Z_L I_M + 2R_P I_M - V_{TR} = 0$$

From Equation 18 with $V_{RX} = 0$

$$V_{TR} = \frac{Z_O V_{2W}}{Z_L} \quad \text{(EQ. 23)}$$

Substituting Equation 23 into Equation 22 and simplifying.

$$E_G = -V_{2W} \left[\frac{Z_L + 2R_P + Z_O}{Z_L} \right] \quad \text{(EQ. 24)}$$

Substituting Equation 12 into Equation 10 and defining $\Delta I_M = -V_{2W}/Z_L$ results in Equation 25 for V_{TX} .

$$V_{TX} = \frac{V_{2W}}{2} \left[\frac{Z_L - 2R_P}{Z_L} \right] \quad \text{(EQ. 25)}$$

Combining Equations 24 and 25 results in Equation 26.

$$G_{2-4} = \frac{V_{TX}}{E_G} = \frac{Z_L - 2R_P}{2(Z_L + 2R_P + Z_O)} = \frac{Z_O}{2(Z_L + 2R_P + Z_O)} \quad \text{(EQ. 26)}$$

A more useful form of the equation is rewritten in terms of V_{TX}/V_{2W} . A voltage divider equation is written to convert from E_G to V_{2W} as shown in Equation 27.

$$V_{2W} = \left(\frac{Z_O + 2R_P}{Z_L + Z_O + 2R_P} \right) E_G \quad \text{(EQ. 27)}$$

Substituting $Z_L = Z_O + 2R_P$ and rearranging Equation 27 in terms of E_G results in Equation 28.

$$E_G = 2V_{2W} \quad \text{(EQ. 28)}$$

Substituting Equation 28 into Equation 26 results in an equation for 2-wire to 4-wire gain that's a function of the synthesized input impedance of the SLIC and the protection resistors.

$$G_{2-4} = \frac{V_{TX}}{V_{2W}} = \frac{Z_O}{(Z_L + 2R_P + Z_O)} = 0.416 \quad \text{(EQ. 29)}$$

Z_L is set to 600Ω, Z_O is programmed with R_S to be 498.76Ω (66.5kΩ/133.33), and R_P is equal to 49.9Ω. This results in a 2-wire to 4-wire gain of 0.416 or -7.6dB.

Transmit Gain Across the System

The transmit gain across the system is defined as the gain from the phone or 2-wire side (V_{2W}) to the PCM highway (DX). Setting the gain of the AK2306 will have to account for the attenuated signal through the HC55185. The system gain is entirely controlled by programming the AK2306. The AK2306 can program the transmit gain across the system from +6dB to -18dB in 1 dB increments (reference Figure 4).

If more precise gain increments are required, the AMPT amplifier can be used to adjust the overall Transmit gain ($Rf/R8$).

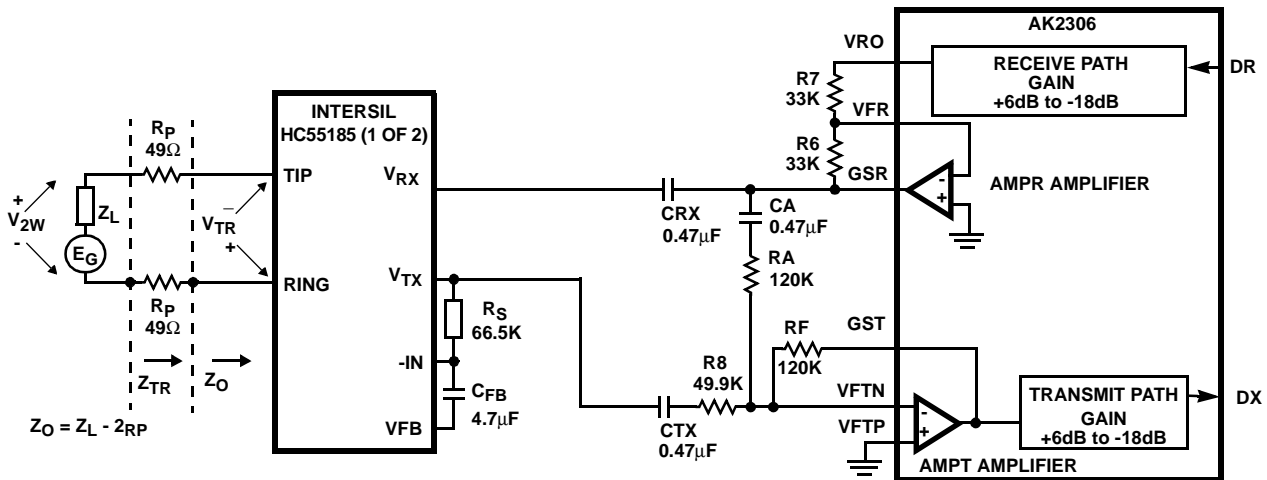

FIGURE 4. RECEIVE GAIN G(4-2), TRANSMIT GAIN (2-4)

Transhybrid Balance G(4-4)

Transhybrid balance is a measure of how well the input signal is canceled (that being received by the SLIC) from the transmit signal (that being transmitted from the SLIC to the CODEC). Without this function, voice communication would be difficult because of the echo.

The signals at V_{GSR} and V_{TX} (Figure 4) are opposite in phase. Transhybrid balance is achieved by summing two signals that are equal in magnitude and opposite in phase into the AMPT amplifier inside the AK2306.

Transhybrid balance is achieved by summing the V_{GSR} signal with the output signal from the HC55185 when proper gain adjustments are made to match V_{GSR} and V_{TX} magnitudes.

For discussion purpose, the AMPT amplifier is redrawn with the external resistors in Figure 5.

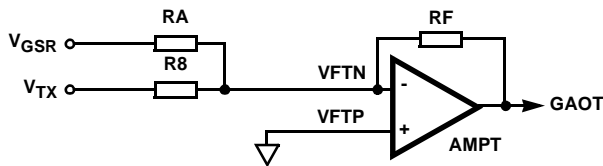

FIGURE 5. TRANSHYBRID BALANCE CIRCUIT

Transhybrid balance is achieved by adjusting the magnitude from both V_{TX} and V_{GSR} so their equal to each other.

The gain across the system is set by the gain through the SLIC (0.416) and the AMPT amplifier through $RF/R8$. RF is randomly selected to be 120k Ω . To achieve a 0dB gain

across the system, with the transmit gain of the AK2306 set to 0dB, we set $R8$ equal to 49.9k Ω , as shown in Equation 30.

$$G_{V_{TX}} = G_{4-4} \left(\frac{RF}{R8} \right) = G_{4-4} \left(\frac{120k}{49.9k} \right) = 0.416(2.404) = 1.0 \quad (EQ. 30)$$

The gain through the AMPT amplifier from V_{GSR} must equal the gain from V_{TX} to achieve transhybrid balance. RA is therefore equal to RF , as shown in Equation 31.

$$G_{V_{GSR}} = V_{GSR} \left(\frac{RF}{RA} \right) = V_{GSR} \left(\frac{120k}{120k} \right) = 1 \quad (EQ. 31)$$

Reference Design of the HC55185 and the AK2306 With a 600 Ω Load

The design criteria is as follows:

- 4-wire to 2-wire gain (DR to V_{2W}) equal 0dB
- 2-wire to 4-wire gain (V_{2W} to DX) equal 0dB
- $R_p = 49.9\Omega$

Figure 6 gives the reference design using the Intersil HC55185 and the AK2306 Dual PCM CODEC. Also shown in Figure 6 are the voltage levels at specific points in the circuit.

Impedance Matching

The 2-wire impedance is matched to the line impedance Z_0 using Equation 1, repeated here in Equation 32.

$$R_S = 133.3 \cdot (Z_L - 2R_p) \quad (EQ. 32)$$

For a line impedance of 600 Ω , R_S equals:

$$R_S = 133.3 \cdot (600 - 98) = 66.9k\Omega \quad (EQ. 33)$$

The closest standard value for R_S would be 66.5k Ω .

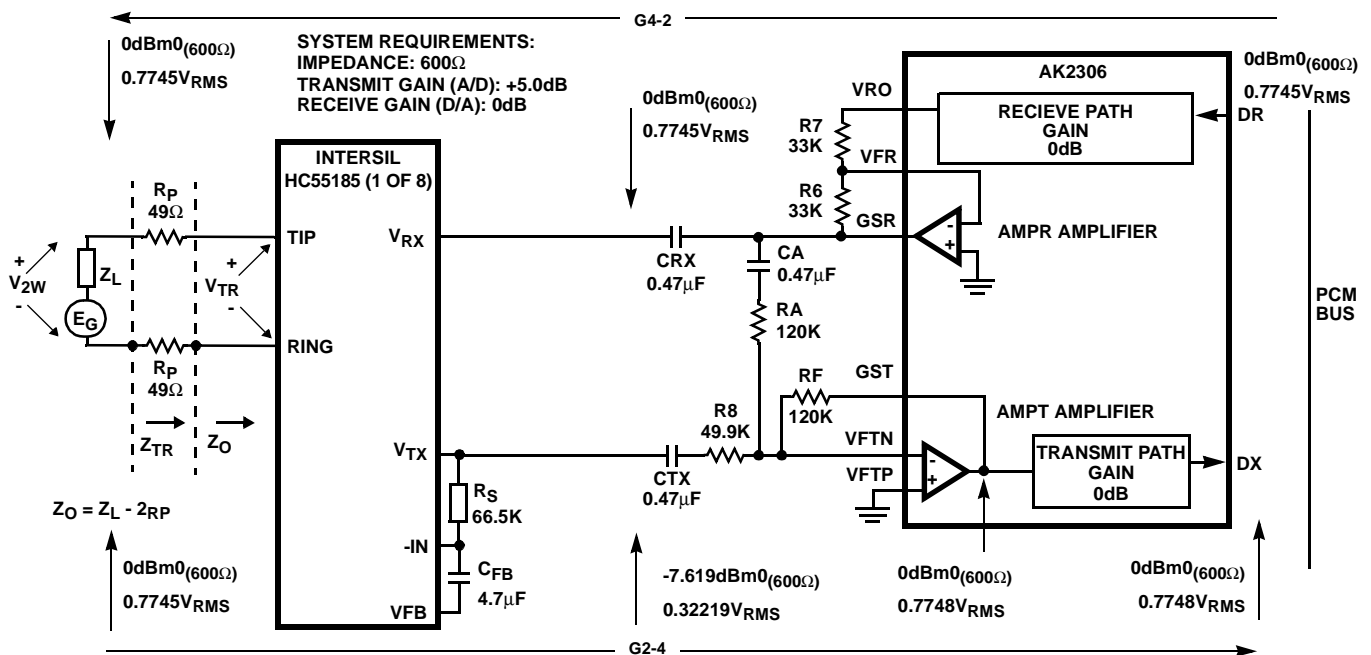

FIGURE 6. REFERENCE DESIGN OF THE HC55185 AND THE AK2306/2306LV WITH A 600 Ω LOAD IMPEDANCE

Reference Design of the HC55185 and the AK2306 With a Complex Load

The design criteria for a Complex load solution are as follows:

- Desired line circuit impedance is $220 + 820j/115nF$
- Receive gain V_{2W} / DR is $-3.5dB$
- Transmit gain DX / V_{2W} is $0dB$
- $0dBm_0$ is defined as $1mW$ into the complex impedance at $1020Hz$
- $R_p = 49.9\Omega$

Figure 7 gives the reference design using the Intersil HC55185 and the AK2306 Dual PCM CODEC. Also shown in Figure 7 are the voltage levels at specific points in the circuit. Note: The transmit gain of the system is $0dB$ ($-1.79dB_{(897\Omega)} = -3.5dB_{(600\Omega)}$) as explained in the following section.

Adjustment to Get $-3.5dBm_0$ at the Load Referenced to 600Ω

The voltage equivalent to $0dBm_0$ into 897Ω ($0dBm_{(897\Omega)}$) is calculated using Equation 34 (897Ω is the impedance of complex load at $1020Hz$).

$$0dBm_{(897\Omega)} = 10\log\frac{V^2}{897(0.001)} = 0.9471V_{RMS} \quad (EQ. 34)$$

The gain referenced back to $0dBm_{(600\Omega)}$ is equal to:

$$GAIN = 20\log\frac{0.9471V_{RMS}}{0.7745V_{RMS}} = 1.747dB \quad (EQ. 35)$$

The adjustment to get $-3.5dBm_0$ at the load referenced to 600Ω is:

$$Adjustment = -3.5dBm_0 + 1.747dBm_0 = -1.75dB \quad (EQ. 36)$$

The voltage at the load (referenced to 600Ω) is given in Equation 37

$$-1.75dBm_{(600\Omega)} = 10\log\frac{V^2}{600(0.001)} = 0.63306V_{RMS} \quad (EQ. 37)$$

Setting the Receive Path Gain equal to $-1dB$ and adjusting $R6/R7$ with standard resistor values results in a voltage of $0.62969V_{rms}$ or $-1.70dBm_0$ (600Ω).

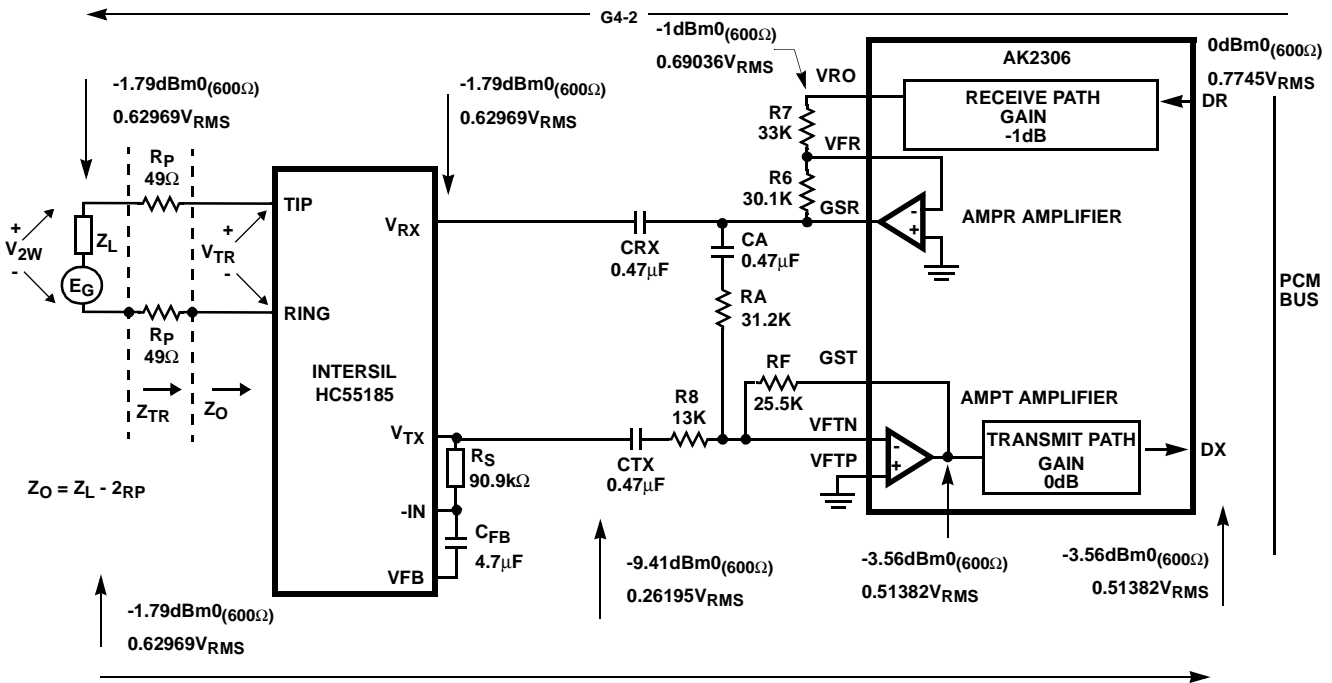

FIGURE 7. REFERENCE DESIGN OF THE HC55185 AND THE AK2306 WITH A COMPLEX LOAD IMPEDANCE

All Intersil U.S. products are manufactured, assembled and tested utilizing ISO9000 quality systems. Intersil Corporation's quality certifications can be viewed at www.intersil.com/design/quality

Intersil products are sold by description only. Intersil Corporation reserves the right to make changes in circuit design, software and/or specifications at any time without notice. Accordingly, the reader is cautioned to verify that data sheets are current before placing orders. Information furnished by Intersil is believed to be accurate and reliable. However, no responsibility is assumed by Intersil or its subsidiaries for its use; nor for any infringements of patents or other rights of third parties which may result from its use. No license is granted by implication or otherwise under any patent or patent rights of Intersil or its subsidiaries.

For information regarding Intersil Corporation and its products, see www.intersil.com